

## SES 單層式彈簧回縮螺栓拉伸器



- 此類型螺栓拉伸器適用於10.9等級的螺栓。
- 主軸會其自動的回縮。
- 安全斷裂裝置。
- 鍍鎳表面塗層，延長使用壽命。
- 不佔使用空間，容易攜帶操作。
- 快速裝卸螺帽。

★亦可依客戶訂製

### Single -Stage, Spring return, Hydraulic Bolt Tensioner

- ※SES-series single stage for 10.9
- ※Automatic piston return : return of the piston into end position after pre-tensioning.
- ※Safety fracture device : In case of wrong use or failure the safety fracture device keeps uncontrolled energy inside the tool - the safety for the staff increases significantly..
- ※Nickel coating which prevents a corrosion of the components.
- ※Design for using not occupy space and easily handle design.
- ※Quick-Release the stud's nut is wound down against the joint face.
- ★User can order suitable reservoir.

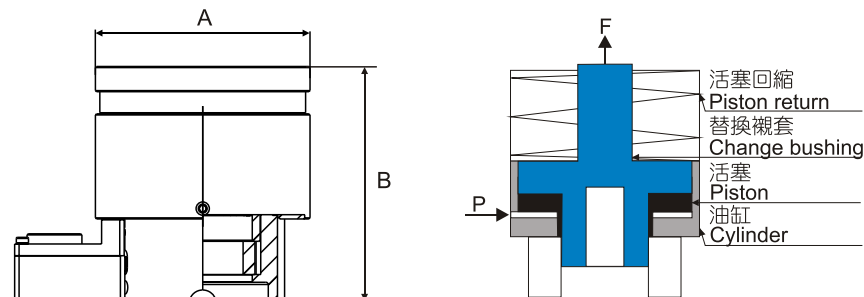

### SES Series

Capacity:  
200-2880 kN

Bolt Range:  
M20-M72  
3/4"-3"

Maximum Operating Pressure:  
1500 bar

## SMSK 雙層式彈簧回縮螺栓拉伸器



- 此類型螺栓拉伸器適用於10.9等級的螺栓。
- 主軸會其自動的回縮。
- 安全斷裂裝置。
- 鍍鎳表面塗層，延長使用壽命。
- 不佔使用空間，容易攜帶操作。
- 快速裝卸螺帽。

★亦可依客戶訂製

### Multi-stage, Spring return, Hydraulic Bolt Tensioner

- ※SMSK-series single stage for 10.9
- ※Automatic piston return : return of the piston into end position after pre-tensioning.
- ※Safety fracture device : In case of wrong use or failure the safety fracture device keeps uncontrolled energy inside the tool - the safety for the staff increases significantly..
- ※Nickel coating which prevents a corrosion of the components.
- ※Design for using not occupy space and easily handle design.
- ※Quick-Release the stud's nut is wound down against the joint face.
- ★User can order suitable reservoir.

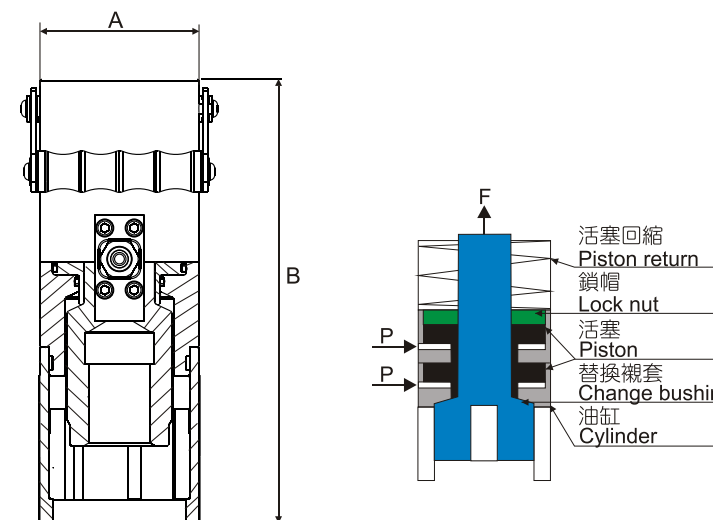

### SMSK Series

Capacity:  
200-2880 kN

Bolt Range:  
M20-M72  
3/4"-3"

Maximum Operating Pressure:  
1500 bar

型號 Model	荷重 Pre-load force		螺紋 Thread		六角對邊 A/F -width		A		本身高 Height B	
	(kN)	(lbs)	(mm)	(in)	(mm)	(in)	(mm)	(in)	(mm)	(in)
	SES-M20	200	44962	M20	3/4	30	1 1/4	65	2.6	121
SES-M24	290	65195	M24	7/8	36	1 7/16	78	3.1	130	5.1
SES-M27	380	85427	M27	1	41	1 5/8	86	3.4	119	4.7
SES-M30	460	103412	M30	1 1/8	46	1 13/16	97	3.8	131	5.2
SES-M33	570	128141	M33	1 1/4	50	2 13/16	106	4.2	136	5.4
SES-M36	670	150622	M36	1 3/8	55	2 3/16	117	4.6	152	6.0
SES-M39	800	179847	M39	1 1/2	60	2 3/8	125	4.9	138	5.4
SES-M42	920	206824	M42	1 5/8	65	2 9/16	134	5.3	143	5.6
SES-M45	1080	242794	M45	1 3/4	70	2 3/4	148	5.8	147	5.8
SES-M48	1220	274267	M48	1 7/8	75	2 15/16	158	6.2	171	6.7
SES-M52	1450	325973	M52	2	80	3 1/8	170	6.7	163	6.4
SES-M56	1680	377679	M56	2 1/4	85	3 1/2	181	7.1	181	7.1
SES-M64	2210	496828	M64	2 1/2	95	3 7/8	210	8.3	195	7.7
SES-M72	2880	647450	M72	3	105	4 5/8	239	9.4	203	8.0

型號 Model	荷重 Pre-load force		螺紋 Thread		六角對邊 A/F -width		A		本身高 Height B	
	(kN)	(lbs)	(mm)	(in)	(mm)	(in)	(mm)	(in)	(mm)	(In)
	SMSK-M20	200	44962	M20	3/4	30	1 1/4	47	1.9	169
SMSK-M24	290	65195	M24	7/8	36	1 7/16	60	2.4	200	7.9
SMSK-M27	380	85427	M27	1	41	1 5/8	65	2.6	210	8.3
SMSK-M30	460	103412	M30	1 1/8	46	1 13/16	72	2.8	204	8.0
SMSK-M33	570	128141	M33	1 1/4	50	2 13/16	79	3.1	216	8.5
SMSK-M36	670	150622	M36	1 3/8	55	2 3/16	83	3.3	250	9.8
SMSK-M39	800	179847	M39	1 1/2	60	2 3/8	91	3.6	265	10.4
SMSK-M42	920	206824	M42	1 5/8	65	2 9/16	98	3.9	272	10.7
SMSK-M45	1080	242794	M45	1 3/4	70	2 3/4	106	4.2	273	10.7
SMSK-M48	1220	274267	M48	1 7/8	75	2 15/16	112	4.4	290	11.4
SMSK-M52	1450	325973	M52	2	80	3 1/8	123	4.8	336	13.2
SMSK-M56	1680	377679	M56	2 1/4	85	3 1/2	131	5.2	356	14.0
SMSK-M64	2210	496828	M64	2 1/2	95	3 7/8	150	5.9	357	14.1
SMSK-M72	2880	647450	M72	3	105	4 5/8	168	6.6	406	16.0