

S Series

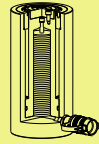

Capacity:
10-200 ton

Stroke:
25-150mm

Maximum Operating Pressure:
700 bar

S液壓單動，標準型千斤頂

- 可360度全方位使用設計。
- 主軸及液壓缸內壁硬路處理耐磨、抗腐蝕；並能增加密封性及使用壽命。
- 強力彈簧加速主軸回縮速度。
- 特殊軟質環設計，防止主軸偏 心荷載；避免磨耗刮傷油缸。
- 防塵環減少污染物附著。
- 上螺帽保護主軸超揚昇。
- 表面粉體塗裝美觀抗腐蝕、防銹。
- 各型號均含SQB-3/8UF快速接頭及防塵蓋。

Single-Acting, General Cylinders

- ※Designed for use in all positions.
- ※Hard chrome plated plunger and inner of barrel resists wear and corrosion, it also be more closed and extending cylinder life.
- ※Maximum sized springs speed piston return and increase spring life.
- ※Special soft ring reduces wear caused by off-center loads.
- ※Plunger wiper reduces contaminant.
- ※Stop ring for piston blow-out protection.
- ※Powder coat finish for increased corrosion resistance and antirust.
- ※All cylinders are equipped with SQB-3/8UF female coupler & dust cap.

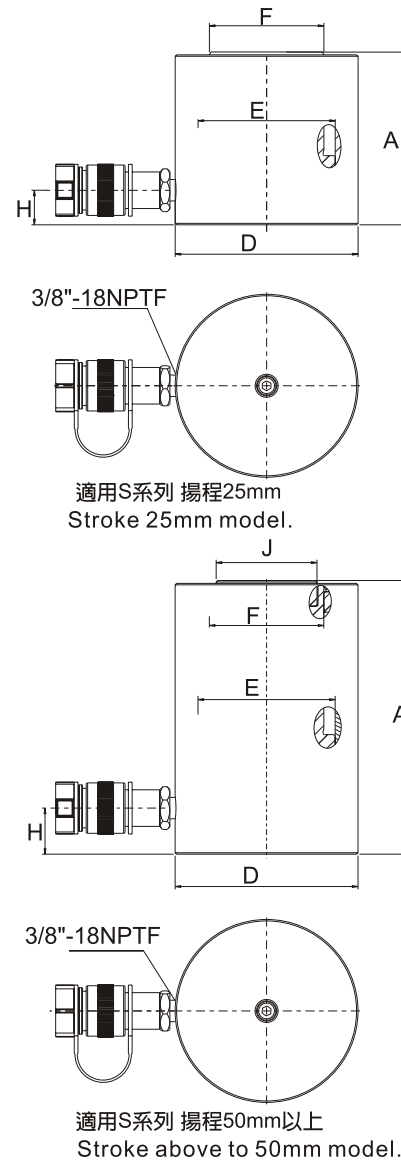

	焊提把 Weldable		活動提把 Removable strap handles
	吊環螺栓 Eyebolt		螺牙式活動提把 Thread

提把型式 Handle type	
(S) : 標準配件 standard equipped	
(O) : 選配 option	
● 焊提把 Weldable	▲ 活動提把 Removable strap handles
★ 吊環螺栓 Eyebolt	■ 螺牙式活動提把 Thread

提把型式 Handle type (O) (S)	型號 Model Number	外部尺寸 Outer Dimension											
		能力 Cylinder Capacity ton (kN)	揚程 Stroke (mm)	受壓面積 Effective Area (cm ²)	總油量 Oil Capacity (cm ³)	本身高 Collapsed Height A (mm)	伸長總高 Extended Height (mm)	外徑 Outside Dia. D (mm)	內徑 Cylinder Bore Dia. E (mm)	主軸直徑 Plunger Dia. F (mm)	底部前進 油孔位置 Base to Adv. Port H (mm)	墊塊直徑 Saddle Dia. J (mm)	重量 Weight (kg)
	S10-25	10 (101)	25.0	14.46	36.1	80.0	105.0	70.0	42.93	38.1	19.5	—	2.4
	S10-50		50.0	14.46	72.3	130.0	180.0	57.0	42.93	38.1	19.5	—	2.5
	S10-75		75.0	14.46	108.4	155.0	230.0	57.0	42.93	38.1	19.5	35	3.1
	S10-100		100.0	14.46	144.6	180.0	280.0	57.0	42.93	38.1	19.5	35	3.4
	S10-125		125.0	14.46	180.7	205.0	330.0	57.0	42.93	38.1	19.5	35	4.0
	S10-150		150.0	14.46	216.9	230.0	380.0	57.0	42.93	38.1	19.5	35	4.2
	S20-25	20 (198)	25.0	28.26	70.7	80.0	105.0	90.0	60.00	50.00	17.0	—	3.7
●	S20-50		50.0	28.26	141.3	135.0	185.0	79.0	60.00	50.00	22.0	—	4.9
●	S20-75		75.0	28.26	212.0	160.0	235.0	79.0	60.00	50.00	22.0	40	5.6
●	S20-100		100.0	28.26	282.6	185.0	285.0	79.0	60.00	50.00	22.0	40	6.3
●	S20-125		125.0	28.26	353.3	210.0	335.0	79.0	60.00	50.00	22.0	40	7.0
●	S20-150		150.0	28.26	423.9	235.0	385.0	79.0	60.00	50.00	22.0	40	7.7
	S30-25	30 (294)	25.0	42.00	105.0	85.0	110.0	99.0	73.15	57.15	19.0	—	5.0
	S30-40		40.0	42.00	210.0	85.0	125.0	99.0	73.15	57.15	22.5	—	7.4
●	S30-50		50.0	42.00	210.0	145.0	195.0	99.0	73.15	57.15	22.5	—	7.6
●	S30-75		75.0	42.00	315.0	170.0	245.0	99.0	73.15	57.15	22.5	49.5	7.8
●	S30-100		100.0	42.00	420.0	195.0	295.0	99.0	73.15	57.15	22.5	49.5	8.9
●	S30-125		125.0	42.00	525.0	220.0	345.0	99.0	73.15	57.15	22.5	49.5	10.0
●	S30-150	150.0	42.00	630.0	245.0	395.0	99.0	73.15	57.15	22.5	49.5	11.0	
●	S30-55	30 (269)	55.0	38.46	212.0	105.0	160.0	100.0	70.00	60.00	14.0	—	8.0
●	S50-25	50 (498)	25.0	71.21	178.0	95.0	120.0	127.0	95.25	79.50	24.0	—	8.8
●	S50-35		35.0	71.21	356.0	85.0	120.0	127.0	95.25	79.50	24.0	—	9.5
●	S50-50		50.0	71.21	356.0	120.0	170.0	127.0	95.25	79.50	24.0	—	10.5
●	S50-50B		50.0	71.21	356.0	105.0	155.0	127.0	95.25	79.50	19.0	—	9.5
●	S50-75		75.0	71.21	534.0	190.0	265.0	127.0	95.25	79.50	32.0	71.5	16.8
●	S50-100		100.0	71.21	712.0	215.0	315.0	127.0	95.25	79.50	32.0	71.5	18.2
●	S50-125	125.0	71.21	890.1	240.0	365.0	127.0	95.25	79.50	32.0	71.5	19.9	
●	S50-150	150.0	71.21	1068.1	265.0	415.0	127.0	95.25	79.50	32.0	71.5	21.4	
▲ ●	S100-25	100 (933)	25.0	133.27	333.1	100.0	125.0	177.0	130.30	104.90	20.0	—	16.9
▲ ●	S100-50		50.0	133.27	666.3	160.0	210.0	177.0	130.30	104.90	30.0	84	26.8
▲ ●	S100-100		100.0	133.27	1332.7	204.0	304.0	177.0	130.30	104.90	30.0	84	36.8
▲ ●	S100-125		125.0	133.27	1665.8	235.0	360.0	177.0	130.30	104.90	30.0	84	40.6
▲ ●	S100-150		150.0	133.27	1999.0	260.0	410.0	177.0	130.30	104.90	30.0	84	44.3
▲ ★	S150-50		150 (1407)	50.0	200.96	1004.8	200.0	250.0	215.0	160.00	115.00	50.0	99
▲ ★	S150-100	100.0		200.96	2009.6	250.0	350.0	215.0	160.00	115.00	50.0	99	60.0
▲ ★	S150-150	150.0		200.96	3014.4	300.0	450.0	215.0	160.00	115.00	50.0	99	68.9
▲ ★	S200-50	200 (1984)	50.0	283.38	1416.9	200.0	250.0	255.0	190.00	135.00	50.0	115	71.6
▲ ★	S200-100		100.0	283.38	2833.0	250.0	350.0	255.0	190.00	135.00	50.0	115	85.0
▲ ★	S200-150		150.0	283.38	4250.7	300.0	450.0	255.0	190.00	135.00	50.0	115	98.5