

RSSM Series

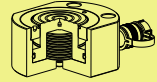

Capacity:
5-150 ton

Stroke:
6-16 mm

Maximum Operating Pressure:
700 bar



RSSM-50

- RSSM-50 搭配 SQB-3/8UF 快速接頭。
- ※ RSSM-50 is fitting with a SQB-3/8UF.



RSSM 液壓單動，超薄型千斤頂

- 扁平設計適用於窄小空間作業需求。
- 底座螺孔便於固定。
- 溝槽式主軸表面，不需加裝墊塊。
- 主軸及液壓缸內壁硬鉻處理耐磨、抗腐蝕。
- 強力彈簧加速主軸回縮速度。
- 防塵環減少污染物附著。
- 上螺帽保護主軸超揚昇。
- 表面粉體塗裝美觀抗腐蝕、防銹。
- 各型號均含 SQB-3/8UF 快速接頭及防塵蓋。

Single-Acting, Low Height, Flat Cylinders

- ※ Compact and flat design for use where in a narrow space.
- ※ Mounting holes permit easy fixturing.
- ※ Grooved plunger ends require no saddle.
- ※ Hard chrome plated plunger and inner of barrel resists wear and corrosion.
- ※ Maximum sized springs speed piston return and increase spring life.
- ※ Plunger wiper reduces contaminant.
- ※ Stop ring for piston blow-out protection.
- ※ Powder coat finish for increased corrosion resistance and antirust.
- ※ Come with SQB-3/8UF female coupler & dust cap.

	焊提把 Weldable
	吊環螺栓 Eyebolt
	活動提把 Removable strap handles
	螺牙式活動提把 Thread

提把型式 Handle type	
(S) : 標準配件 standard equipped	
(O) : 選配 option	
● 焊提把 Weldable	
★ 吊環螺栓 Eyebolt	
▲ 活動提把 Removable strap handles	
■ 螺牙式活動提把 Thread	

提把型式 Handle type	型號 Model Number	外部尺寸 Outer Dimension					
		能力 Cylinder Capacity	揚程 Stroke	受壓面積 Effective Area	總油量 Oil Cap.	本身高 Collapsed Height	伸長總高 Extended Height
(S)		ton(kN)	(mm)	cm ²	cm ³	A (mm)	(mm)
	RSSM-50	5 (45)	6	6.5	4	32	38
	RSSM-100	10 (101)	12	14.5	18	43	54
	RSSM-200	20 (201)	11	28.7	32	51	62
	RSSM-300	30 (295)	13	42.1	55	58	71
	RSSM-500	45 (435)	16	62.1	99	66	82
●	RSSM-750	75 (718)	16	102.6	164	79	95
●	RSSM-1000	90 (887)	16	126.7	203	85	101
●	RSSM-1500	150 (1386)	16	198.1	317	100	116

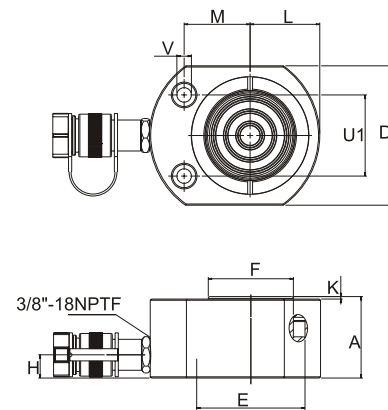

型號 Model Number	外部尺寸 Outer Dimension								底座孔徑 Base Mounting Hole			
	外徑 Outside Diameter	內徑 Cylinder Bore Diam.	主軸直徑 Plunger Diam.	底部前進 油孔位置 Base to Adv. Port	凸出高度 Plunger Protrusion from Base	偏心位置 Plunger to Base	魚眼位置 Plunger to Mtg. Hole	總重 Weight	魚眼孔距 Hole Pitch	孔徑 Hole Diam.	魚眼 Counter Bore Diam.	魚眼深度 Counter Bore Depth
	D (mm)	E (mm)	F (mm)	H (mm)	K (mm)	L (mm)	M (mm)	(kg)	U1 (mm)	V (mm)	(mm)	(mm)
RSSM-50	58 x 41	28.7	25.4	16	1	20	22	1.0	28.5	5.5	7.9	4.3
RSSM-100	82 x 55	42.9	38.1	19	1	27	34	1.4	36.6	7.1	10.7	7.9
RSSM-200	101 x 76	60.5	50.8	19	1	39	39	3.1	49.3	10.0	15.1	9.9
RSSM-300	117 x 95	73.2	63.4	19	2	47	44	4.5	52.3	10.0	15.9	11.2
RSSM-500	140 x 114	88.9	69.8	19	2	57	53	6.8	66.5	11.9	19.0	12.7
RSSM-750	165 x 139	114.3	82.6	19	2	69	66	11.3	76.2	13.5	20.6	14.2
RSSM-1000	178 x 153	127.0	92.2	19	2	76	74	14.5	76.2	13.5	20.6	14.2
RSSM-1500	215 x 190	158.8	114.3	23	2	95	82	26.3	117.3	13.5	20.6	14.2

RSSM 系列配件

- 強力磁力組成多樣性高度。
- 適用底矮型空間作業增加高度時使用。

RSSM series Accessories

- ※ Various height magnetic adapters.
- ※ Perfect for low clearance areas needing a little height boost.

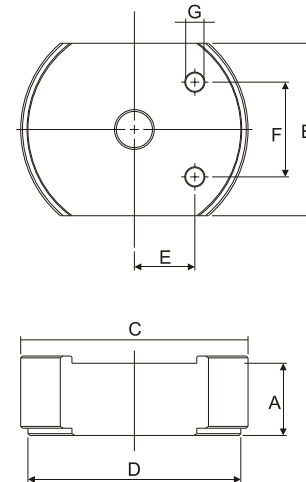

最大操作壓力 10000psi / 700bar
Maximum working pressure 10000psi / 700bar



型號 Model No.	油缸型號 Cylinder Model	油缸高度 Cylinder Height	墊塊尺寸 Adapter Dimension								重量 Weight
			A	B	C	D	E	F	G		
		(in) (mm)	(in) (mm)	(in/mm)	(in/mm)	(in/mm)	(in/mm)	(in/mm)	(in/mm)	(in/mm)	(kg)
XKRSSM5-6	RSSM-50	1.25 32.0	0.1 6.4	1.6 / 41.4	2.5 / 64.7	2.3 / 58.7	0.5 / 13.6	1.1 / 28.5	0.2 / 5.1	0.1	
XKRSSM5-12			0.5 12.7								0.2
XKRSSM5-25			1.0 25.4								0.5
XKRSSM5-31			1.3 31.8								0.6
XKRSSM10-9	RSSM-100	1.69 43.0	0.4 9.9	2.2 / 55.6	3.6 / 90.6	3.3 / 82.6	0.8 / 20.5	1.4 / 36.6	0.3 / 7.1	0.3	
XKRSSM10-20			0.8 20.0								0.7
XKRSSM10-39			1.6 39.9								1.4
XKRSSM20-9	RSSM-200	2.00 51.0	0.4 9.9	3.0 / 76.2	4.3 / 109.6	4.0 / 101.6	1.1 / 28.4	1.9 / 49.3	0.4 / 10.1	0.6	
XKRSSM20-20			0.8 20.0								1.1
XKRSSM20-39			1.6 39.9								2.2
XKRSSM30-9	RSSM-300	2.28 58.0	0.4 9.9	3.8 / 95.3	4.9 / 125.6	4.6 / 117.6	1.3 / 33.4	2.1 / 52.3	0.4 / 10.1	0.8	
XKRSSM30-20			0.8 20.0								1.6
XKRSSM30-39			1.6 39.9								3.2

油/液壓缸-動力單元(泵)組合
建議您基本安裝包含油壓缸、公/母快速接頭、油管、壓力錶、壓力錶接頭及驅動泵浦。
相關技術諮詢請和就近的SUN RUN 服務中心取得連繫。

Hydraulic Cylinder and Pump Sets
Basic system set-up include cylinder, male/female coupler, hose, pressure gauge, gauge accessories and pump.
Please connect SUN RUN office nearest to you for advice and technical assistance in the layout of your ideal.

控制閥 Control Valve
可搭配例如SV-82類的針閥來控制油壓缸上升和下降的速度 (請參考 SV-系列)
Fitting needle valve such as SV-82 is used to control cylinder speed during lifting and lowering. (See SV-Series)